

# Instruction manual for LaserCut 18 / 40 / 60

ELECTRONIC SPEED CONTROLLER FOR BRUSHLESS MOTORS

Official distribution in Europe by [www.cnc-modellsport.de](http://www.cnc-modellsport.de)

## Connections:

The speed controller can be connected to motor by direct soldering or with high quality connectors. Always use new connectors, which should be soldered carefully to the cables and insulated with Heat Shrink Tubing. It is possible to extend the cables to the motor battery pack up to a maximum of 8 inches. Deans Ultra or other high quality connectors are recommended for connecting the motor battery pack to the controller.

- Solder controller to the motor wires
- Solder appropriate connectors to the Battery wires
- Insulate all Solder connections with Heat Shrink Tubing
- Plug the 3 Pin connector into the receiver throttle channel

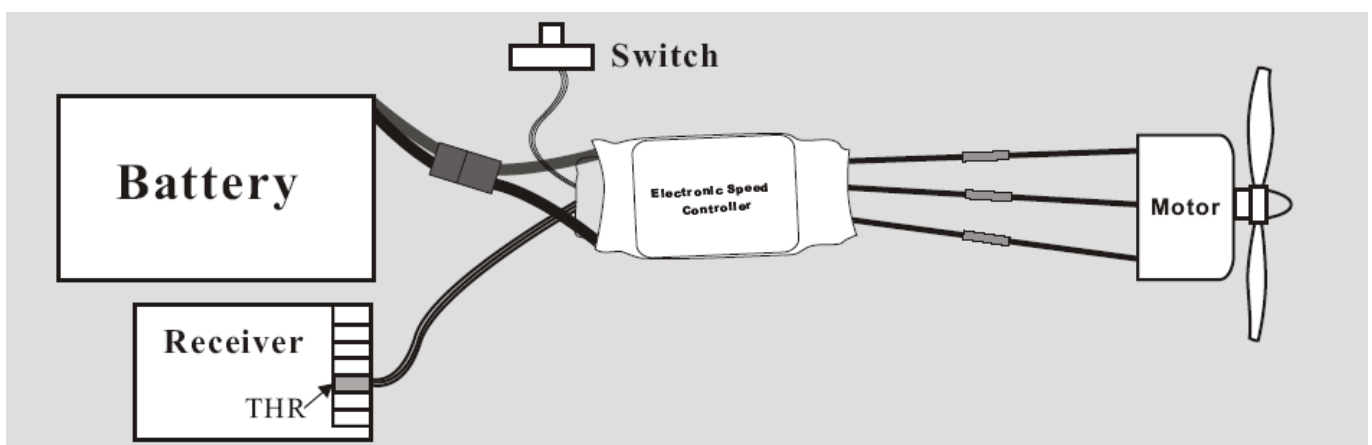

## Installing the Controller:

Install the speed controller in the model so that it is isolated from vibration and shock, using

Velcro or double sided foam tape. Allow space around it for cooling. Make sure that there is sufficient cooling of the motor and speed controller by ducting air through adequate cooling holes from the outside airflow. Main power packs should be connected at one attempt.

- Locate the controller to Avoid multiple touches of the connectors when installing a fresh motor battery pack.

## Using the controller:

- Switch “ON” the transmitter and check the throttle channel settings are +/-100% (for computer radios). For Radios program the “Servo Reverse” function on the throttle channel. Set the throttle to “closed” or brake position
- Switch on the speed controller. For speed controllers without BEC, switch on the power to receiver.
- You must hear a ‘beep’. **Between switching on the switch and the ‘beep’ the throttle stick must not be moved.** If you do not hear a ‘beep’, switch off the switch, disconnect the power connectors, wait for 5 seconds and repeat the procedure of connecting and switching on.
- If you do not hear ‘beep’ again, check the following:
  - 1).Is 3 Pin connector plugged in throttle channel?
  - 2).Is the throttle stick in “closed” position (OFF)?
  - 3).Is the throttle channel in ‘normal’ position?
- You will hear the ‘beep’ during the first switch-on of the controller only. When you switch-off the speed controller without disconnecting the motor battery pack, you will not hear the beep after next switch-on.
- The position of ‘full throttle’ will be adjusted automatically.
- **Warning: Once the Motor Battery Pack is connected, handle the model with extreme care!** Ensure that you are well clear of the propeller at all times. Rotating propellers are extremely dangerous!
- Always Connect the motor battery pack just before flight and disconnect it immediately after landing the model.
- **Warning: Even when the switch is ‘off’ remember the Motor Battery pack may be connected, handle the model with extreme care and stay well clear of the Propeller!**

## Setting the Propeller Brake On or Off:

- The speed controller is supplied with the ‘brake’ activated. If you want to turn off the brake, do the following:
  - 1).Switch on the transmitter and move the stick to full throttle
  - 2).Connect the main power pack and turn on the receiver switch (if used)
  - 3).Wait 5 seconds
  - 4).After 5seconds you will hear 5 single “beeps”
  - 5).Swiftly move the throttle stick to the closed position; you will hear two “beeps”
  - 6).The brake is now turned off

## Setting the Timing Mode:

- It is possible to set two timing modes with these speed controllers
  - 1).Soft timing-for 2,4,6, pole motors. Soft timing gives maximum efficiency
  - 2).Hard timing only for 6 and more pole motors
- Hard timing in creases both the motor revolutions and the current (up to 20%) with the same prop and battery pack when compared to soft timing. This is more suitable for faster flying models.
- Always use soft timing for first flights. If the temperature of the batteries, speed controller and motor are below 50°C degrees following the first flights it is possible to test the system using the hard timing mode. Do not use hard timing with 2 pole motors.
- Hard Timing is recommended for use with Model Motors outrunner motors-even for the first flights.
- The Speed controllers are supplied with soft timing-to change the timing:
  - 1).Switch on the transmitter and move the stick to full throttle
  - 2).Connect the main power pack and turn on the receiver switch and wait 5 seconds.
  - 3).After 5 seconds you will hear 4 “beeps”
  - 4).After further 5 seconds you will hear 5 “beeps” for soft timing
  - 5).OR 5 double “beeps” for hard timing
  - 6).The required timing is set by moving the throttle stick to the closed throttle position
  - 7).The new timing is confirmed by a single “beep”(brake on) or a double “beep”(brake off)
- The timing setting will not change after disconnecting the main power pack.

## Notes About Operation:

- Reversing the motor directions is achieved by the exchanging the position of any two wires connected to motor.
- Do Not exceed the 10 cells or 4-5 servos when using the BEC.
- The speed controller will turn-off the motor when the main power pack voltage falls under 5.3V or reaches 0.7V/cell. It depends on which occurs first.
- Temperature overload protection is built into the speed controller, it turns off the motor when the temperature reaches 100°C.
- These speed controllers are equipped with protection functions that take care of correct start and operation of the motor across the whole range of RPM, Current and Voltage.
- Do Not connect the speed controller to just ‘any’ kind of power source. Take care to ensure the right polarity of NiCd or NiMh power packs only.
- Do not connect the motor battery to the wrong polarity, the speed controller will be severely damaged.
- Controllers connected to the wrong battery polarity, WILL NOT be covered under the warranty.

## Notes:

- RoHS-Compliant Product.
- Do not dispose Controller in a fire or normal waste.
- CE Tested Product.

## Technical datas:

<b>Model</b>	<b>Size [mm]</b>	<b>Weight [g]</b>	<b>Current / Peak [A]</b>	<b>NiCd, NiMh / Servos</b>	<b>Li-XX / Servos</b>
<b>LaserCut18</b>	49x24x10	21	18 / 25	6/4 ; 8/4 ; 10/2	2/4 ; 3/3
<b>LaserCut40</b>	49x24x10	28	40 / 60	6/5 ; 8/5 ; 10/4 ; 12/3	2/5 ; 3/4
<b>LaserCut60</b>	66x26x11	34	60 / 70	-	-

## Copyrights:

- Document special printed for [www.cnc-modellsport.de](http://www.cnc-modellsport.de)
- All rights reserved by [www.cnc-modellsport.de](http://www.cnc-modellsport.de)